

NOTE: C WILL VARY
 DEPENDING
 ON PITCH AND PIPE
 DIAMETER

ALUMINUM PIPE
 6063 T6
 ASTM B-221

SIZING CHART				
STACK SIZE	A (I.D.)	A (O.D.)	B	C
1.25"	1.75"	1.884"	12"	10.25"
1.5"	2.23"	2.364"	12"	10.8"
2"	2.5"	2.634"	12"	11.125"
3"	3.6"	3.734"	12"	12.5"
4"	4.6"	4.734"	12"	13.625"
5"	5.75"	6"	12"	14.75"

AVAILABLE IN ANY PITCH

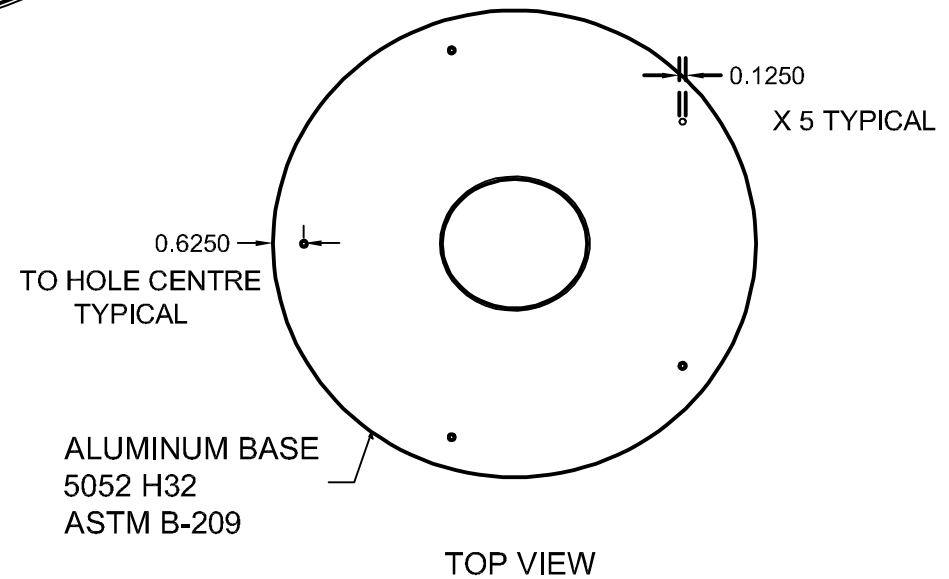
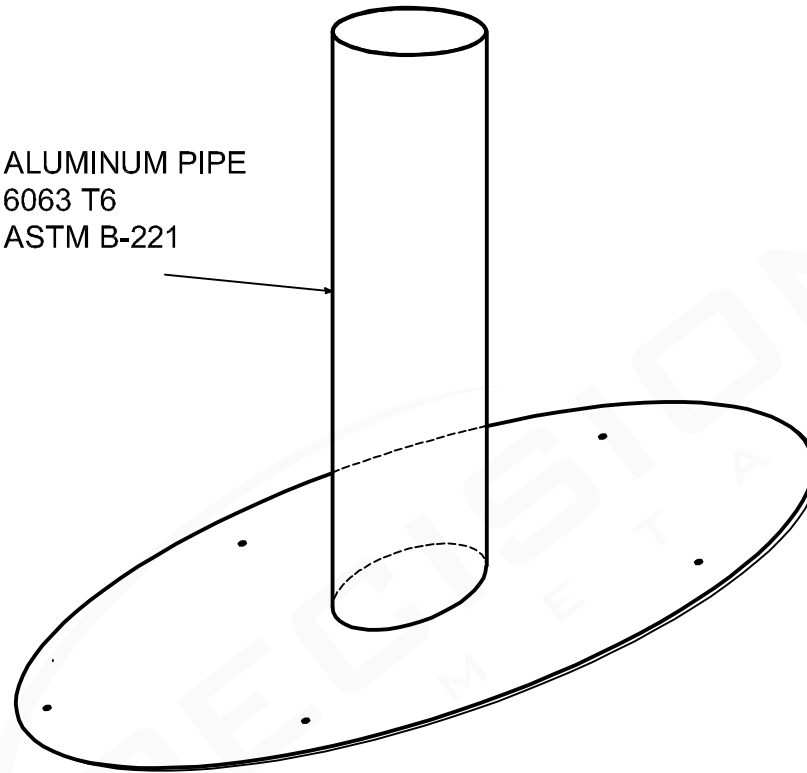
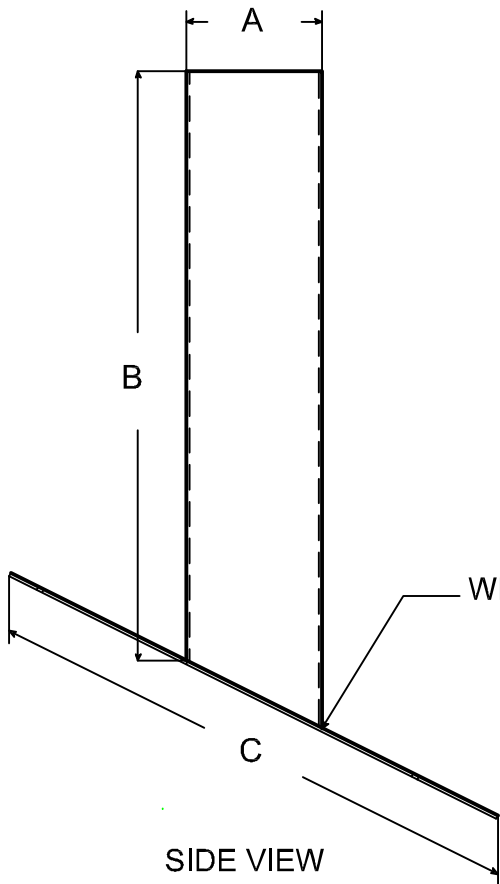

PART
 NAME:

PITCHED STACK ALUMINUM

DRAWN
 BY: D.B.

DATE:
 04/16/21

SCALE:
 NTS

SHEET:



www.precisionmetals.ca